

technical data

Semco® fillet nozzles

Semco® specialty application nozzles

For the application of sealant fillets over lap joints. These nozzles eliminate the need for tooling the sealant with spatulas and, therefore, increase productivity.

The model 425, 426, 427 and 428 nozzles have a built-in step to guide the nozzle along the lap joint to produce a smooth, uniform fillet. The model 429 nozzle has no step and, therefore, provides versatility for use at odd angles and in confined spaces.

These disposable nozzles are precision molded and have a 1/4 NPT male thread to fit Semco® 1, 2.5, 3.5, 6, 8, 12, 20, 32 oz. and 1/10 gallon disposable cartridges. When these nozzles are used in conjunction with a Semco® model 250 sealant gun, a smooth, uniform fillet can be applied each time.

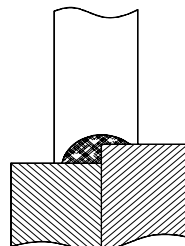
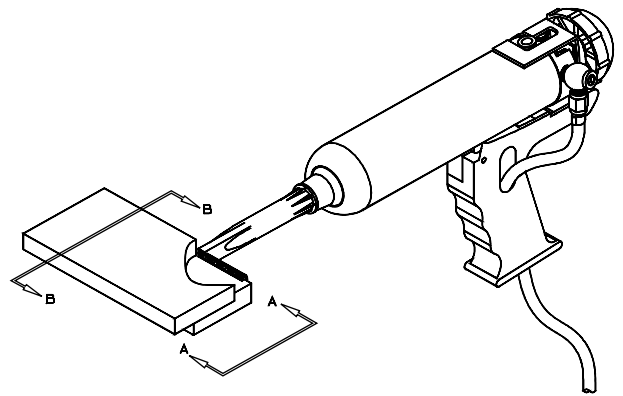
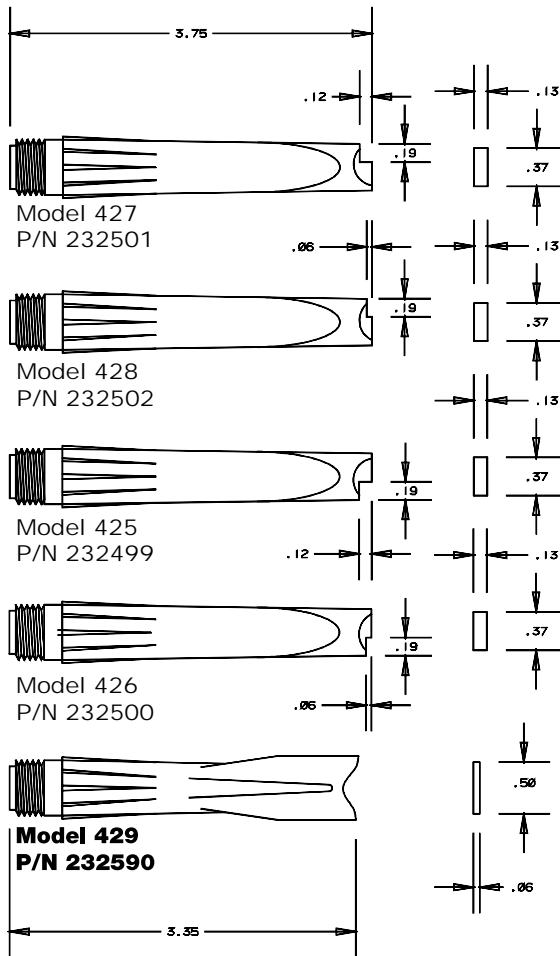

Detail A-A

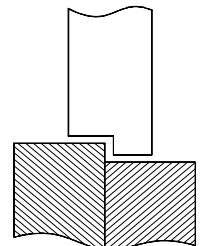

Detail B-B

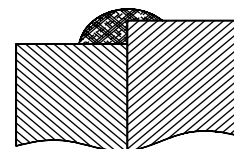

Finished fillet

Nozzles shown above are precision molded of low density polyethylene. All dimensions shown are in inches.

Nozzles shown above are precision molded of low density polyethylene. All dimensions shown are in inches.