

# Techcon Systems TS350 / TS355 Precision Controllers

## User Guide

English Version

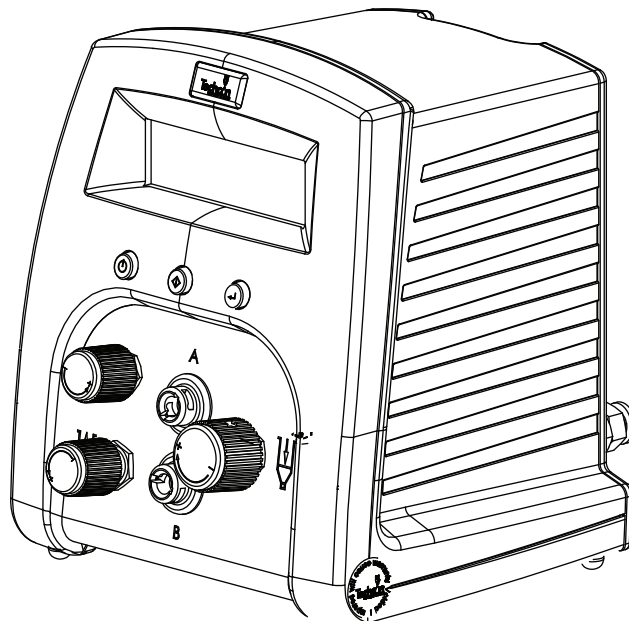

Sales and Service  
Bergdahl Associates, Inc.  
2990 Sutro Street  
Reno, Nevada 89512-1616  
phone: +1 775 323-7542  
[www.bergdahl.com](http://www.bergdahl.com)



1	Safety .....	2 - 3
2	Symbol Definitions .....	3
3	Specifications .....	3
4	Features .....	4
5	Connecting the Unit .....	5
6	Setup Instructions .....	5 - 6
7	Troubleshooting .....	7
8	Maintenance .....	8
9	Spare Parts and Accessories .....	8
10	Warranty .....	8
11	I/O Configuration and End of Cycle Switch .....	9

1 SAFETY

1.1 Intended Use:

*WARNING: Use of this equipment in ways other than those described in this User Guide may result in injury to persons or damage to property. Use this equipment only as described in this User Guide.*

OK International cannot be responsible for injuries or damages resulting from unintended applications of its equipment. Unintended uses may result from taking the following actions:





- Making changes to equipment that has not been recommended in the User Guide
- Using incompatible or damaged replacement parts
- Using unapproved accessories or auxiliary equipment

1.2 Safety Precautions:

- Do not operate this unit in excess of maximum ratings/settings
- Always wear appropriate personal protective clothing or apparel
- Use only the following power adaptor models: PSA15R-240P(ZJ) or PW118RA2403B01, PW118RA2403H01, PW118RA2403M01, PW118RA2403G01
- Care must be taken to prevent the ingress of corrosive or flammable fluid back into the unit. If corrosive or flammable fluids are used, an inline filter (881-000-000) must be installed on the dispenser to help prevent the fluids from being sucked back into the unit
- The fluid being dispensed may be toxic and/or hazardous. Refer to Material Safety Data Sheet for proper handling and safety precautions
- If a piston is not used with the barrel, an inline filter (881-000-000) must be installed on the receiver head to help prevent fluids from being sucked back into the unit. Also do not overfill the barrel and to lay the barrel on its side
- Do not smoke or use open flame when flammable materials are being dispensed

- This equipment is for indoor use only

## 2 SYMBOL DEFINITIONS

Symbol	Definition
	Power On/Off
	Cycle Mode
	Timer
	Vacuum
	Pressure

## 3 SPECIFICATIONS

Size	152mm X 165mm X 178mm (6" X 6.5" X 7")
Weight	1.2 kg (2.6lbs)
Input Voltage	24VDC
Rated Power	10W
Air Input	100 psi (6.9 bar) Max.
Pollution Degree	II
Installation Category	I
Indoor Use	Altitude up to 2,000m (6,562ft)
Operating Temperature	0°C to 50°C (32°F to 122°F)
Storage Temperature	-10°C to 60°C (14°F to 140°F)
Max. Relative Humidity	80% for temperature up to 31°C (87.8°F) Decreasing linearly to 50% relative humidity at 40°C (104°F)
Air Output	TS350 = 0-100 psi (0-6.9 bar) TS355 = 0-15 psi (0-1.03 bar)
Vacuum	406mm (16") of Hg
Timer	0.008-60.000 seconds
Cycle Mode	Timed, Interrupt, Teach, Purge
Timing Repeat Tolerance	+/- 0.001%
Cycle Rate	1,200 cycles/min.
LCD	<sup>3</sup> 20 X 4 display segments

**4 FEATURES**

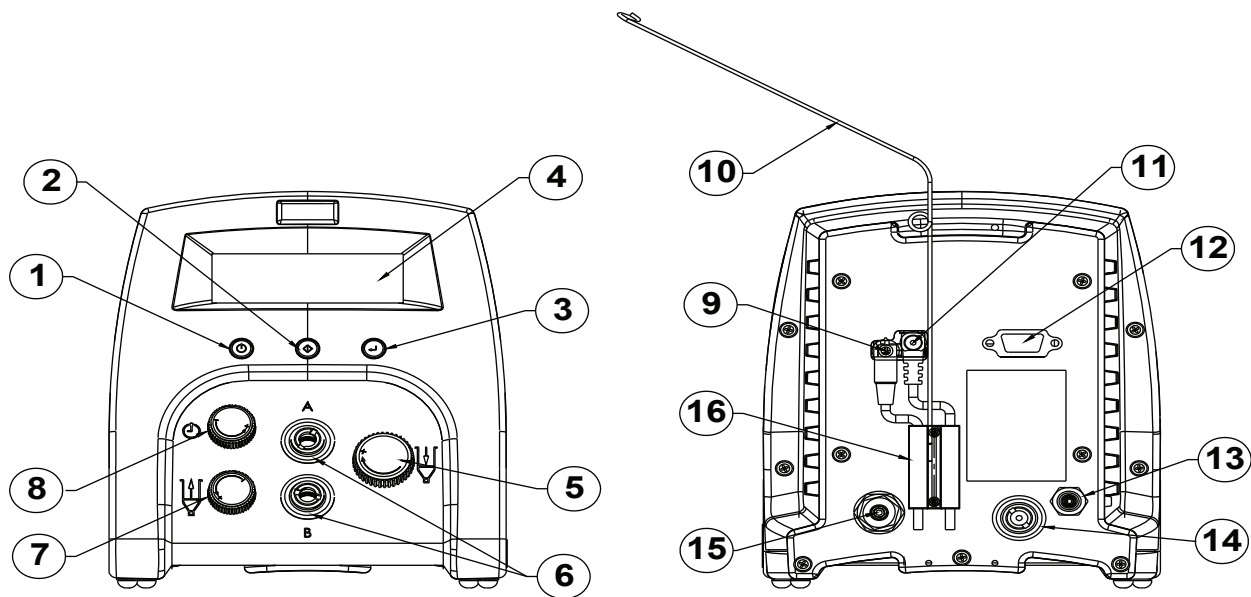

**Figure 1.0**

<b>Items</b>	<b>Description</b>
1	Power Button
2	Mode Button
3	Reset Button
4	Display
5	Air Pressure Regulator
6	Pulsed Air Outlet
7	Vacuum Control
8	Setup Control Knob
9	Foot Switch Receptacle
10	Receiver Head air hose holder
11	Power Receptacle
12	I/O Connection
13	Exhaust Port
14	Accessory Air Outlet
15	Air Inlet
16	Cord Lock

Techcon Systems  
TS350 / TS355

**5 CONNECTING THE UNIT**

*CAUTION: A 5-micron filter TSD800-6, not included, must be installed with the unit to ensure proper air filtration.*

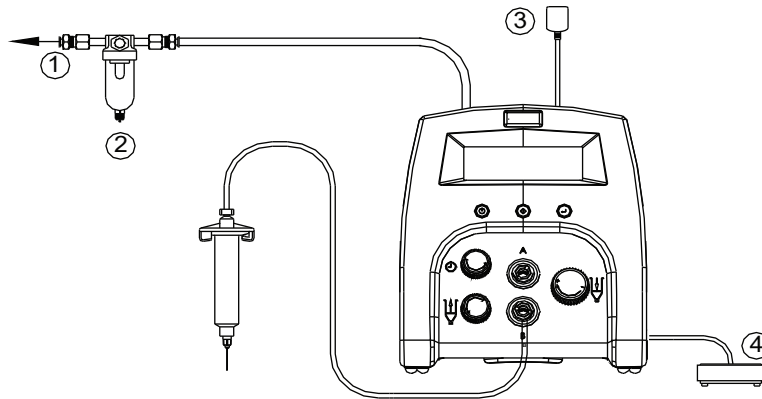

**Figure 2.0**

Items	Description
1	To Air Source
2	Air Filter (Not Included)
3	Power Adapter
4	Foot Switch

**6 SETUP INSTRUCTIONS**

Refer to Figure 1.0

**6.1 Manual/Purge Dispense Cycle Setting:**

1. Turn on the unit by pressing the Power button (1)
2. Press the Mode button (2) until “PURGE” appears on the Display.
3. Turn up the air pressure by rotating the Air pressure regulator knob (5) until the desired pressure is indicated on the Display
4. After filling the barrel or using pre-packaged adhesive, attach syringe to receiver head assembly. Make certain that the syringe locks into place
5. Connect the plug end of the receiver head assembly to one of the air dispense outlet (6).
6. If vacuum “suck back” is needed, rotate the Vacuum regulator (7) counter clockwise until the desired vacuum pressure is indicated on the Display
7. Press and hold the Foot switch to activate dispensed cycle. (The Manual/Purge Mode is now activated)

**6.2 Automatic Dispense Cycle Setting**

**6.2.1 Program selection**

1. Press the reset button (3) until “P:” is flashing
2. Rotate the Setup Control Knob (8) to select desired program

**6.2.2 Time setting**

1. Press the Mode button (2) to select “TIMED” mode
2. Press and release the reset button (3) until the colon cursor (:) in the “TIME:” is flashing.
3. Rotate the Setup control knob (8) to set the desired dispense time
4. Depress Foot switch to activate timed dispensed cycle

### 6.3 Teach Mode Setting

In the teach mode, the unit will accumulate time as long as the foot switch is depressed. This is helpful in determining dispense time required when dispense output is unknown.

1. Press the Mode button (2) to select “TEACH” mode.
2. Press and release the reset button (3) until the dispense time = 0.000S
3. Press and hold down Foot switch. Dispense time will accumulate during this time.
4. Release Foot switch when proper amount of fluid is dispensed.
5. Press the Mode button (2) to switch the “TIMED” mode.
6. The dispenser is now set to repeat this time cycle.

### 6.4 Multiple Shots Setting:

Up to ten separate individual or sequenced shots can be stored in the TS350/TS355.

1. Follow steps in section “6.2 Automatic Dispense Cycle Setting” to set dispense time in desired programs.
2. Press both the Reset button (3) and the Power button (1) simultaneously to activate sequence program mode.
3. Rotate the Setup Control knob to select total number of program to be dispensed in sequence
4. Press both the Reset button (3) and Power button (1) to exit Multiple Shots mode.

### 6.5 Cycle Counter

The cycle counter records the numbers of automatic dispense cycle being activated. Up to 65,535 cycles can be recorded. This number is shown at the lower right hand corner of the LCD. To reset the counter, press and hold the Reset button (3) and the Mode button (2) simultaneously until the counter shows “0”.

### 6.6 Change Pressure and Vacuum Unit Display

1. Press and release the reset button (3) until the colon cursor (:) in the “PRESSURE:” or “VACUUM:” is flashing
2. Rotate the Setup control knob (8) to select desired unit display

## 7 TROUBLESHOOTING

<b>PROBLEM</b>	<b>POSSIBLE CAUSE</b>	<b>CORRECTION</b>
<ul style="list-style-type: none"> <li>• LCD does not light</li> </ul>	<ul style="list-style-type: none"> <li>• No power input</li> </ul>	<ul style="list-style-type: none"> <li>• Check power cord connections</li> <li>• Turn on power</li> </ul>
<ul style="list-style-type: none"> <li>• System will not actuate</li> </ul>	<ul style="list-style-type: none"> <li>• Foot switch not plugged in or improperly plugged in</li> <li>• Defective foot switch</li> <li>• Broken wire or loose connection inside unit</li> <li>• Defective solenoid</li> <li>• Defective PC board</li> </ul>	<ul style="list-style-type: none"> <li>• Check foot switch connection</li> <li>• Foot switch needs to be repaired or replaced</li> <li>• Unplug power cord and disconnect air supply. Remove cover and check for broken wires or loose connections</li> <li>• Replace solenoid</li> <li>• Replace PC board</li> </ul>
<ul style="list-style-type: none"> <li>• System will not pressurize</li> </ul>	<ul style="list-style-type: none"> <li>• Insufficient air pressure</li> <li>• Air hoses not plugged in</li> <li>• Regulator defective</li> </ul>	<ul style="list-style-type: none"> <li>• Increase air supply pressure</li> <li>• Check connection</li> <li>• Replace regulator</li> </ul>
<ul style="list-style-type: none"> <li>• System will not pull vacuum</li> </ul>	<ul style="list-style-type: none"> <li>• Vacuum setting is too low</li> <li>• Defective solenoid</li> <li>• Defective vacuum venturi</li> <li>• Defective vacuum needle valve</li> </ul>	<ul style="list-style-type: none"> <li>• Increase vacuum setting</li> <li>• Replace solenoid valve</li> <li>• Replace venturi</li> <li>• Replace needle valve</li> </ul>
<ul style="list-style-type: none"> <li>• Inconsistent dispensing</li> </ul>	<ul style="list-style-type: none"> <li>• Air bubbles in adhesive</li> <li>• Dispense time is too low</li> <li>• Dispense needle started to clog</li> </ul>	<ul style="list-style-type: none"> <li>• Reduce vacuum setting</li> <li>• Increase dispensing time</li> <li>• Replace needle</li> </ul>

## **8 MAINTENANCE**

The dispenser is designed and built to be relatively maintenance free. To assure trouble free operation, the following recommendations should be followed:

1. Make certain air supply is clean and dry.
2. Avoid turning barrels upside down or laying barrel so that material may run through air line to internal components.
3. Avoid connecting the unit to excessive moisture or solvent saturation.
4. Avoid connecting air supply exceeding 100 psi (6.9 bar) for the TS350 and 15 psi (1.03 bar) for the TS355.
5. Use only Amyl Alcohol to clean outside surface of the main housing.
6. Use only soft cloth to clean the LCD.

## **9 SPARE PARTS AND ACCESSORIES**

For TS3xx/2xx spare parts and accessories information, please visit the TS3xx/2xx User Guide webpage at <http://www.techconsystems.com>

## **10 LIMITED WARRANTY**

OK International warrants this product to the original purchaser for a period of one (1) year from date of purchase to be free from material and workmanship defects but not normal wear-and-tear, abuse and faulty installation. Defective product or subassembly and components under warranty will be repaired or replaced (at OK International's option) free of charge. Customer with defective product under warranty must contact the nearest OK International office or distributor to secure a return authorization prior to shipping the product to the assigned OK International authorized service center. For nearest OK International office or distributor contact information, please visit [www.techconsystems.com](http://www.techconsystems.com). OK International reserves the right to make engineering product changes without notice.



### 11 I/O Configuration and End of Cycle Switch

During a dispense cycle, an open collector circuit closes and remains closed while the valve is dispensing. Pin 3 and 4 can be as feedback signal to synchronize with other devices. Power from an external source is allowed to pass through the circuit to operate a 5 to 24 VDC load. Power consumption must not exceed 250 mA. The load could be a relay, solenoid, counter, LED, or any device that will operate within a 5 to 24 VDC range and a maximum of 250 mA.

**Note:**

**During the dispense cycle, pin 3 will be grounded. Please make sure the external device (your machine that controls the dispenser/controller) has the same ground as the TS350/355 controller.**

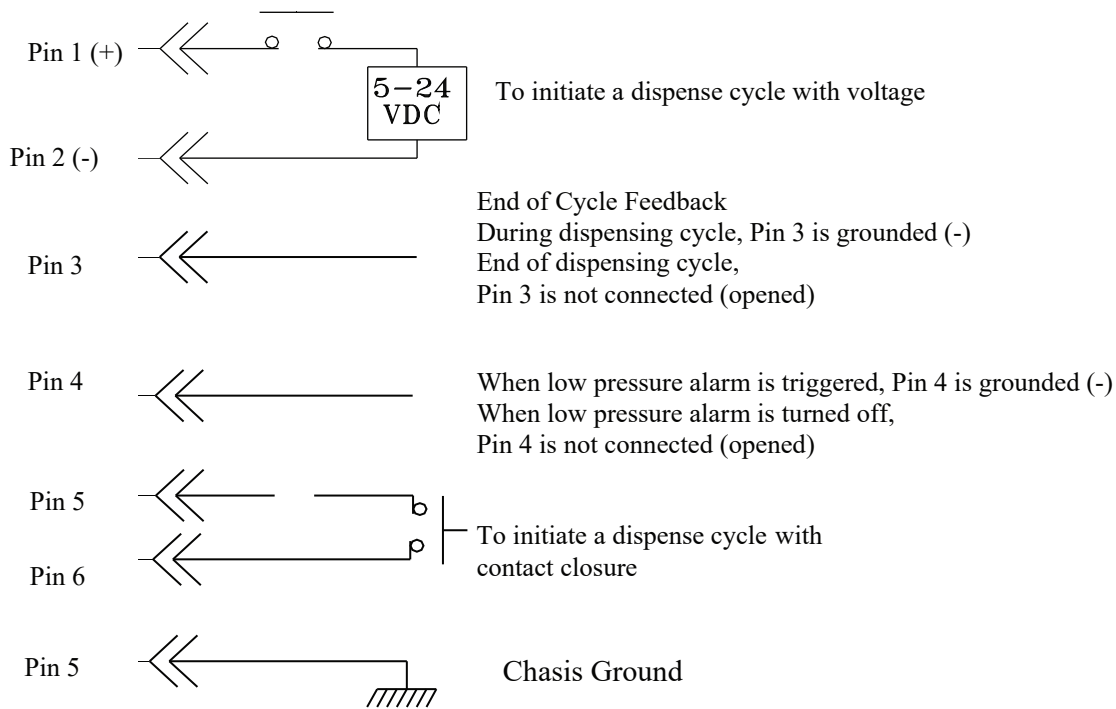

Pin 7, 8, and 9 = Available

Sales and Service  
 Bergdahl Associates, Inc.  
 2990 Sutro Street  
 Reno, Nevada 89512-1616  
 phone: +1 775 323-7542  
 www.bergdahl.com